

Kit di ripristino fanali Philips

Manuale di utilizzo

Contenuto della confezione:

- Pre-trattamento a base d'acqua (water-based pretreatment)
- Soluzione lavafari/polish (headlight cleaner)
- Soluzione brillantante (shine restorer)
- Carta abrasiva: grana 600,1500,2000
- Tovagliette di carta

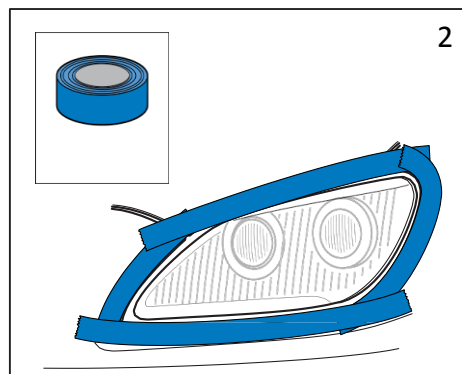
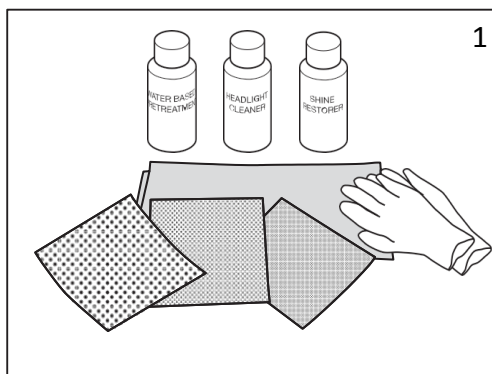

Coprire i bordi del fanale con del nastro adesivo come indicato nell'immagine

Il nastro non è incluso nel kit, se necessario, deve essere acquistato separatamente.

Primo prodotto da utilizzare:
Pre-trattamento a base d'acqua.

Agitare prima dell'uso

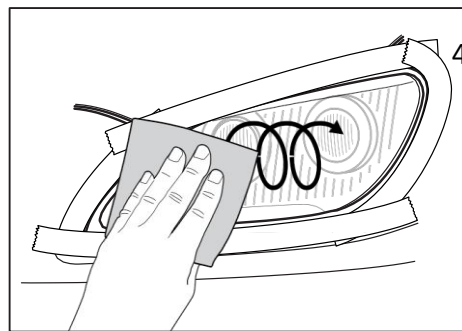
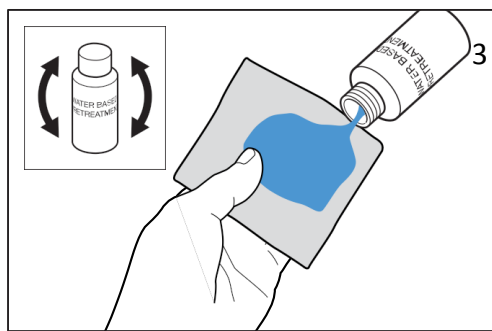

Pulire come indicato nell'immagine

Utilizzare per prima la carta abrasiva con grana 600 se i fanali sono molto rovinati. Altrimenti iniziare il lavoro con la carta con grana 1500. Movimenti verticali dall'alto verso il basso (e viceversa). Applicare su tutta la superficie del fanale fino ad ottenere una finitura uniforme. Se necessario utilizzare dell'acqua per lubrificare il fanale.

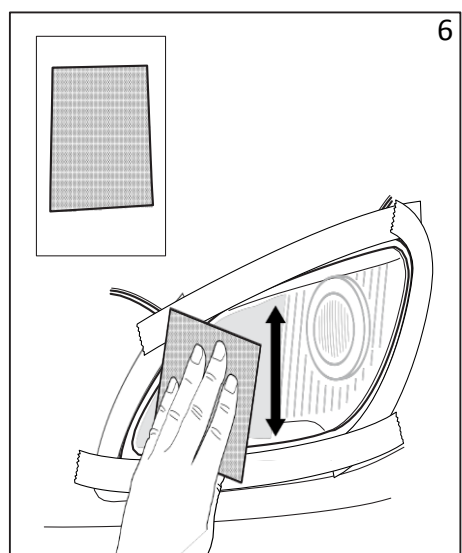
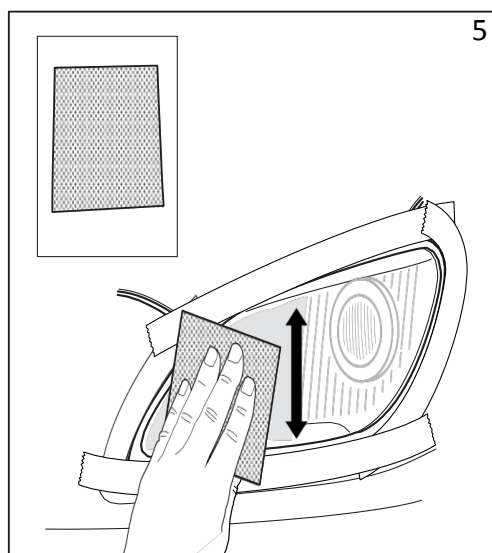

Per finire, utilizzare la carta abrasiva con grana 2000 seguendo lo stesso movimento.

PHILIPS

A questo punto, dopo aver agitato il flaconcino con la soluzione lavafari/polish, versarne quanto basta su una tovaglietta.

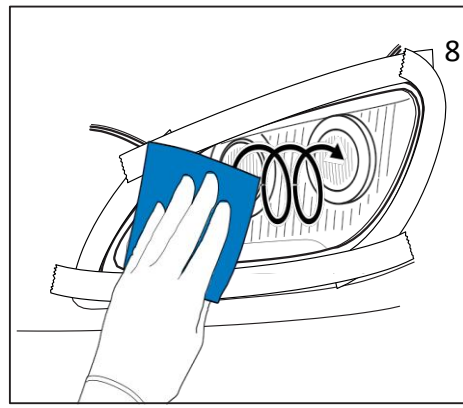
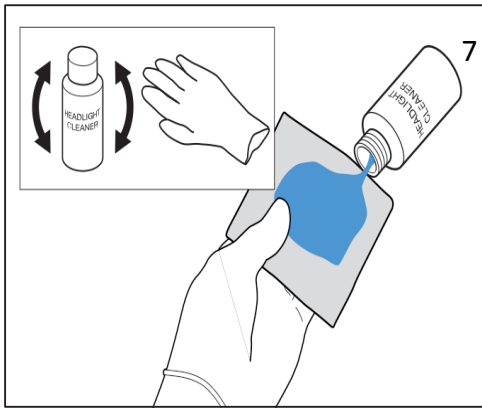

Lucidare con cura i fanali seguendo il movimento come indicato nell'immagine.

Riutilizzare la soluzione pre-trattamento a base d'acqua

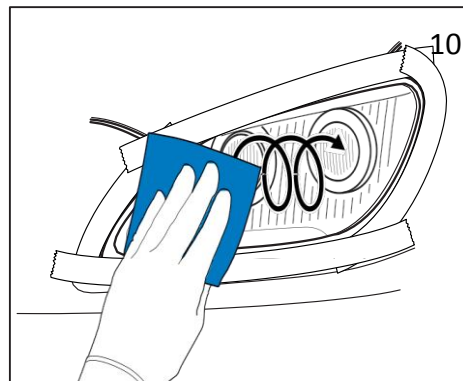
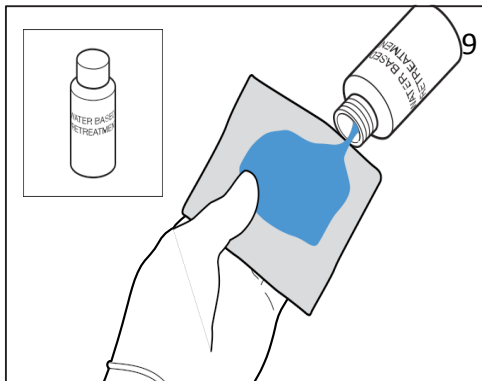

Ripulire i fanali con il pre-trattamento a base d'acqua da eventuali residui della soluzione precedente.

Infine, applicare la soluzione brillantante per almeno due volte.

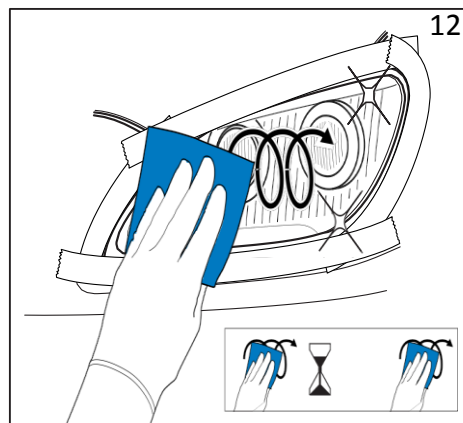
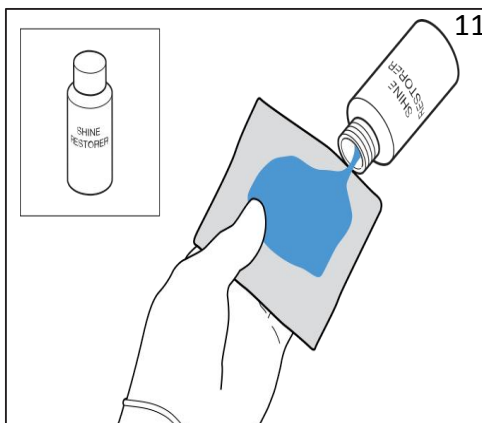

Il prodotto si asciugherà 5 minuti dopo l'applicazione.

Philips Headlight Water Based Pretreatment and Philips Headlight Cleaner/Polish

Inhalation: Do not inhale. If symptoms develop, move individual to fresh air. Seek medical attention if symptoms persist. Product is not known to be a health hazard.

Swallowing: Do not swallow. In case of accidental ingestion, immediately give 2 glasses of water orally and induce vomiting. Seek medical attention.

Skin: Contact may cause minimal skin irritation. Flush skin with generous amounts of water. Seek medical attention if irritation persists.

Eyes: Contact with eyes may cause irritation. Flush eyes gently with generous amounts of water. Seek medical attention if irritation persists.

Philips Headlight Shine Restorer/Preserver:

Inhalation: Do not inhale. If symptoms develop, immediately move individual to fresh air. Seek medical attention if symptoms persist.

Swallowing: Do not swallow product. Seek medical attention. Product is not known to be toxic.

Skin: Wear gloves to protect hands. Wash area with soap and water. Seek medical attention if irritation persists.

Eyes: Contact may cause irritation. Flush eyes gently with water for at least 15 minutes while holding eyelids apart. Seek medical attention.



©2013 Koninklijke Philips Electronics N.V.

All rights reserved.

Philips France

33 rue de Verdun, 92250 Suresnes

Philips Lighting Poland S.A., Pila,

Kossaka 150, O/Pabianice,

ul Partyzancka 66/72

95-200 Pabianice Poland



Your product is designed and manufactured with high quality materials and components, which can be recycled and reused. When this crossed-out wheeled bin symbol is attached to a product it means the product is covered by the European Directive 2002/96/EC. Please inform yourself about the local separate collection system for electrical and electronic products.

Please act according to your local rules and do not dispose of your old products with your normal household waste. The correct disposal of your old product will help prevent potential negative consequences for the environment and human health.